

Modelling Melanin Biosynthesis Pathway with Petri Nets

Mohammed Ashraff Hathibelagal, Reggie Davidrajuh

*Electrical Engineering and Computer Science, University of Stavanger,
Stavanger, Norway.*

Email: MA.Hathibelagal@stud.uis.no; Reggie.Davidrajuh@uis.no

Abstract - Melanin is a UV radiation-absorbing pigment that is responsible for variation in skin color. The melanin synthesis pathway is a series of chemical reactions that lead to the formation of melanin. By creating a mathematical model of the pathway, some questions can be answered: What are the relative quantities of the three different melanin produced given specific initial conditions? What are the factors responsible for an increase or decrease in a specific type of melanin produced? How do genetic defects lead to different kinds of albinism or hyperpigmentation disorders? How do skin-whitening products that target the pathway affect it? The paper develops a Petri Net model of the biological pathway to synthesise melanin in human skin. The Petri net model successfully simulated several pathway properties, and the results matched the experimental findings described in several papers. The model also simulated defects in the pathway that lead to different types of oculocutaneous albinism in humans. Hence, this paper shows that the easy to use Petri Nets could also be used to model complex biological processes.

Keywords - Melanin synthesis pathway, Petri Nets, GPen-SIM.

I. INTRODUCTION

It is widely accepted that all modern humans evolved from ancestral populations in Africa, who had dark skin to protect themselves against the UV rays of the sun [1]. However, we observe that there is tremendous diversity in the color of the human skin today. In general, ethnic groups living close to the equator have dark skin tones, while those living near the poles have lighter skin tones. This paper presents a Petri net model that can simulate and explain the causes of this diversity.

Melanin is a UV radiation-absorbing pigment that is responsible for variation in skin colour. Although all humans continue to have approximately the same number of cells that produce melanin [2], the amount produced varies significantly. As one might expect, people with darker skin tones have cells that produce more of it.

The melanin synthesis pathway is a series of chemical reactions that lead to the formation of melanin. The reactions involve several enzymes, amino acids, and simple molecules. And the end product contains three different kinds of melanin: reddish yellow Pheomelanin, brown Eumelanin, and black Eumelanin [3], [4].

By developing a Petri Net model of the pathway, the following questions could be answered:

- 1) What are the relative quantities of the three different kinds of melanin produced given specific initial conditions?
- 2) What factors are responsible for an increase or decrease in a specific type of melanin produced?
- 3) How do genetic defects lead to different kinds of albinism or hyperpigmentation disorders?
- 4) How do skin-whitening products that target the pathway affect it?

Because pathways consist of chemical reactions, usually with discrete amounts of chemicals involved, Petri Nets can model them with a high degree of accuracy.

Related Works: Petri nets have been used to model biological pathways since the early 1990s. One of the seminal papers in this domain modelled the pathway for the metabolism of fructose using a standard Petri net [5]. Since then, models have been created for a variety of pathways. Examples include the pathway for the metabolism of sucrose in potato tubers [6], the signal transduction pathway for apoptosis [7], and the TLR4 pathway [8].

Petri Nets: Due to space restrictions, this paper does not present the basics of Petri Nets. The interested reader is referred to [9] for basic definitions.

A tool known as General-purpose Petri Net Simulator (GPenSIM) is used to implement Petri Nets. GPenSIM is described in [10] and can be downloaded from the website [11].

A modular Petri Net model is developed in this paper. Developing a Modular Petri Net model in the GPenSIM environment is discussed in [12] and [13].

II. TOWARDS DEVELOPING A PETRI NET MODEL OF MELANIN BIOSYNTHESIS PATHWAY

A modular approach was followed to design the Petri Net model. The Petri Net was divided into several segments (modules), and each module was responsible for generating an important intermediate product of melanin synthesis. Figure 1 shows all the important modules and the direction of flow of tokens.

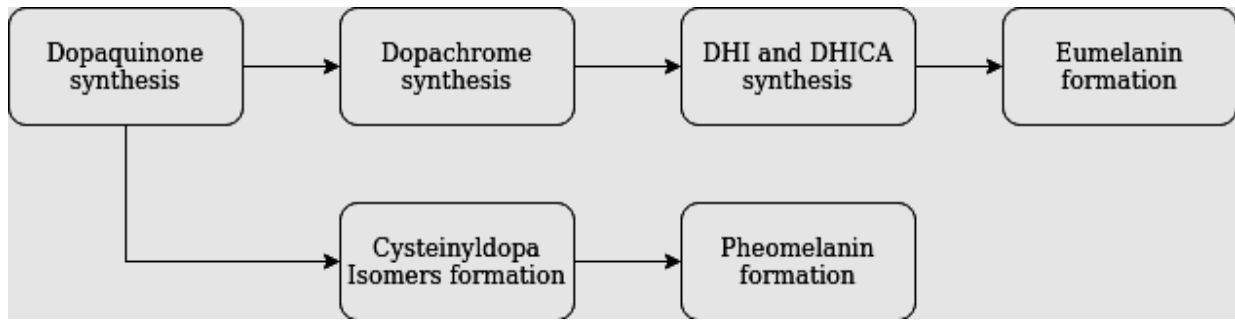

Fig. 1. Important segments

TABLE I. ABBREVIATIONS

Full name	Abbreviation
Oculocutaneous Albinism Type 2 gene	OCA2
Solute Carrier Family 45 Member 2 gene	SLC45A2
5,6-dihydroxyindole-2-carboxylic acid	DHICA
5,6-dihydroxyindole	DHI
5,6-Indolequinone-2-carboxylic acid	IQCA

A three-stage approach was followed in this project:

- Stage-I “Developing the Petri Net skeleton”: In the first stage, a Timed Petri Net with constant firing times was created. All the proteins, amino acids, and simple molecules involved in the pathway were modelled as places. All the chemical reactions, including those catalysed by enzymes, were represented using transitions. Using stoichiometric diagrams of the reactions, weights were assigned to the arcs in the net.
- Stage-II “Stochastic Firing Times”: In the second stage of the project, the rate constants of important reactions were used to assign approximate firing times to transitions in the Petri net. Furthermore, all the firing times were set to follow exponential distributions, in accordance with Gilbert et al [14].
- Stage-III “Colored Tokens”: Of the three different kinds of melanin that are generated, the black and brown eumelanins are generated within the same branch of the pathway. Colored tokens were used to distinguish between the different kinds of melanin.

GPenSIM supports distributing the model logic between the Petri Net (“hard wiring”) and processor files (“soft coding”) [15]. Hence, all the behaviors that cannot be (or difficult to) put on the Petri Net model are coded in the processor files. For example, the preferential behaviors and the behavior of genes that directly or indirectly control details such as pH levels and activity levels of various enzymes, are coded in the processor files.

Several genes, enzymes, and other molecules present in the pathway have lengthy names. Conventionally-used abbreviations are used in this paper to improve readability. Their functions in the pathway are explained as necessary later in the paper. Table-I shows the abbreviations.

As a mathematical model (Petri Net, in this paper) is an abstraction of the real system, not all the characteristics of melanin biosynthesis pathways are taken into the model. Only the important characteristics are represented in the model. Either as variables in the processor files or as places in the Petri Net. The physical properties or chemical behaviors not related to the pathway are ignored.

III. THE PETRI NET MODEL

The Petri Net model consists of the following modules:

- 1) L-Tyrosine to Dopaquinone
- 2) Dopaquinone to Dopachrome
- 3) L-Dopa to Dopaquinone
- 4) Dopachrome to DHICA and DHI
- 5) Eumelanin Synthesis
- 6) Pheomelanin Synthesis

The following subsection present the modules.

A. L-Tyrosine to Dopaquinone

The melanin synthesis pathway begins with an amino acid called L-Tyrosine and a hydroxyl radical. An enzyme, or catalyst, called Tyrosinase converts them into an intermediate product called Dopaquinone [16].

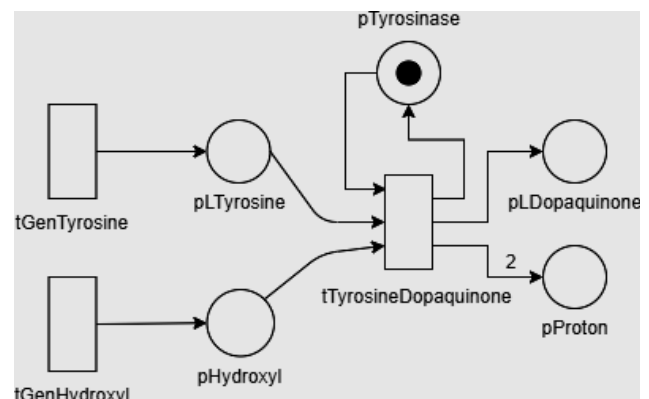

Fig. 2. L-Tyrosine to Dopaquinone

L-Tyrosine and the hydroxyl radical come from outside the pathway. Humans derive L-Tyrosine from food, and can also synthesize it themselves from Phenylalanine, another amino acid which is obtained from food. So tokens for the L-Tyrosine and hydroxyl places are supplied using generators.

The place for Tyrosinase is initialized with a single token. Because it acts as an enzyme, the token is regenerated every time the transition fires, as can be seen in figure 2.

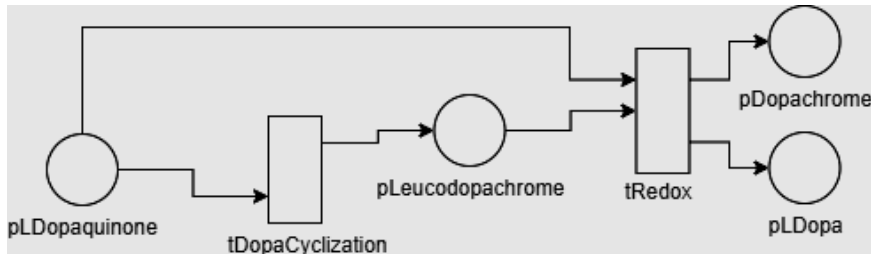

Fig. 3. Dopaquinone to Dopachrome

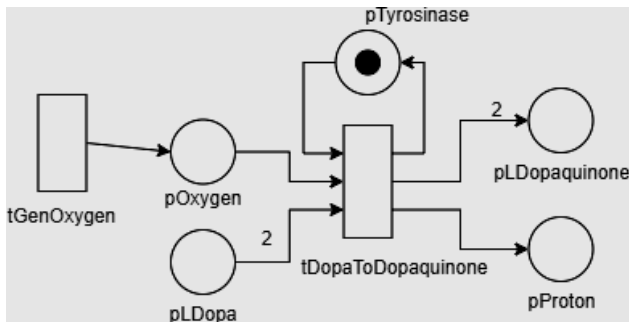

Fig. 4. L-Dopa to Dopaquinone

B. Dopachrome to Dopachrome

Dopaquinone is quite reactive, and spontaneously converts to Leucodopachrome, which in turn reacts with the remaining Dopaquinone to form Dopachrome and L-Dopa [17]. This part of the Petri net doesn't need to be initialized with any tokens.

C. L-Dopa to Dopaquinone

Once there are two units of L-Dopa available, they are used to generate more Dopaquinone with the help of Tyrosinase and oxygen. A generator is used to generate tokens for the place for oxygen.

D. Dopachrome to DHICA and DHI

Dopachrome is an unstable compound and spontaneously forms DHI [18]. But, in the presence of another enzyme called TRP-2, which is a Tyrosinase Related Protein, Dopachrome is also converted to DHICA. This part of the Petri net needs to be initialized with one token in the place for TRP-2.

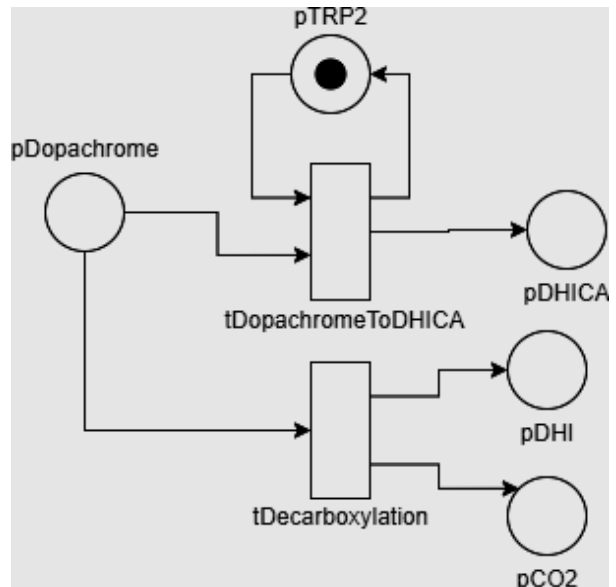

Fig. 5. Dopachrome to DHICA and DHI

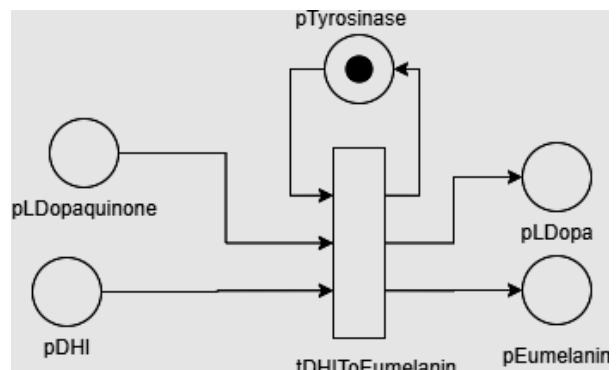

Fig. 6. DHI to Eumelanin

E. Eumelanin Synthesis

Once there's DHI available, Dopaquinone can react with it in the present of Tyrosinase to form black Eumelanin and more L-Dopa [19]. The place for Tyrosinase shown in Figure 6 is, in the implementation, the same place as shown earlier, so there is no need for any additional tokens during initialization.

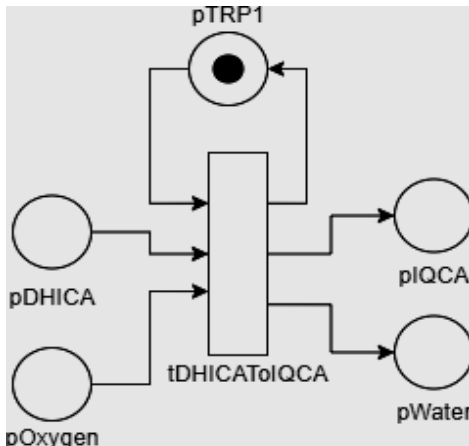

Fig. 7. DHICA to IQCA

In the presence of another Tyrosinase Related Protein, called TRP-1, DHICA reacts with oxygen to form IQCA and water. TRP-1 is an enzyme, and its place needs to be initialized with one token. This token is regenerated after the reaction.

IQCA too can react with Dopaquinone in the presence of Tyrosinase to form Eumelanin. But this time, the Eumelanin is much lighter, and is hence referred to as brown Eumelanin in the literature.

Additionally, any remaining DHICA too reacts with Dopaquinone in the presence of Tyrosinase to form brown Eumelanin.

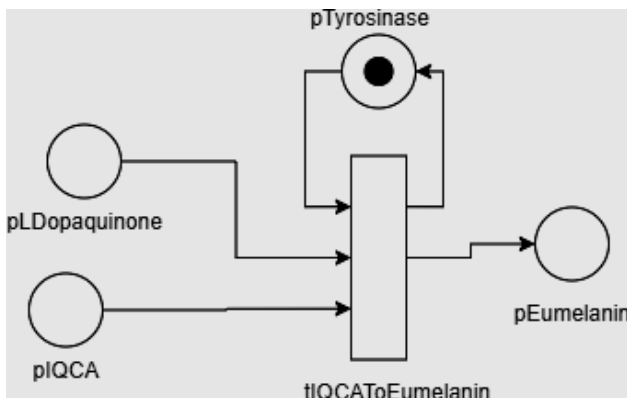

Fig. 8. IQCA to Eumelanin

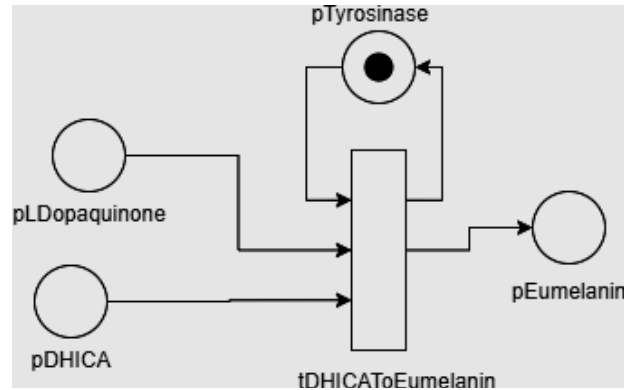

Fig. 9. DHICA to Eumelanin

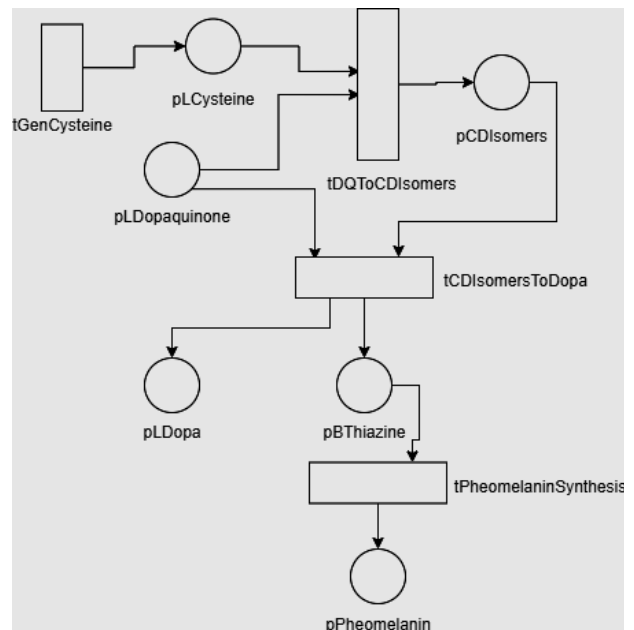

Fig. 10. Dopaquinone to Pheomelanin

F. Pheomelanin Synthesis

If there's an amino acid called L-Cysteine present in the cell, Dopaquinone forms Cysteinyldopa isomers instead of Leucodopachrome. The isomers react with the remaining Dopaquinone to form intermediate compounds such as Benzothiazine, which finally lead to the production of a reddish yellow form of melanin called Pheomelanin. There's more LDopa generated in this part of the pathway.

Because L-Cysteine comes from outside the pathway, a generator is used to model its availability.

It is also worth noting that no enzymes are necessary for this part of the melanin synthesis pathway. So long as there's L-Cysteine and Dopaquinone available, Pheomelanin will be generated in the cell.

IV. PETRI NET IMPLEMENTATION SPECIFICS

This section presents some implementation specifics. Due to brevity, this paper does not show any implementation code. For reproducibility, the complete code is available on the web [20]. Also, the simulator GPenSIM can be freely downloaded from the following website [11].

A. Firing Times of the Transitions

All the transitions in the Petri net were initially set to have constant firing times. This is for testing purposes, thus lead to a very crude model of the pathway because the rate constants of the reactions involved were extremely important in deciding the final form and amount of melanin produced. Ito et al [21] have experimentally measured the rate constants, and those values were used to improve the accuracy of this model.

The rate constants of the important reactions are as listed in table II.

TABLE II. REACTION RATES

Reaction	Rate constant
Conversion of Dopachrome to Leucodopachrome	3.8 S^{-1}
Conversion of Leucodopachrome to Dopachrome	$5.3 \times 10^6 \text{ S}^{-1}$
Formation of Cysteinyldopa isomers	$3 \times 10^7 \text{ S}^{-1}$
Conversion of Cysteinyldopa isomers to BTCA	$8.8 \times 10^5 \text{ S}^{-1}$

As can be seen in the table, some reactions are several orders of magnitude faster than others. Therefore, it didn't seem reasonable to use the rate constants directly. Instead, it was decided to classify the firing times into four types: VERY_FAST, FAST, SLOW, and VERY_SLOW and assigning more usable and intuitive time units to them. Each of these time units, furthermore, was picked randomly from an appropriate exponential distribution to further improve the accuracy of the model. Functions available in MATLAB's statistics and machine learning toolbox were used to do so.

Table III shows the types and the μ of the exponential distributions.

TABLE III. TIME UNITS

Type	VERY FAST	FAST	SLOW	VERY SLOW
μ	2	4	10	20

B. Limits

Tokens for L-Tyrosine and L-Cysteine were generated using generators. Consequently, the Petri net had an unlimited supply of these compounds. This, however, is not the case in the human body. Therefore, to regulate the maximum number of tokens present in the places for L-Tyrosine and L-Cysteine, the common preprocessor file was

used. If the number of tokens exceeded a preset threshold, which could be adjusted using global variables, the generator transitions were not allowed to fire.

Furthermore, L-Cysteine acts as an inhibitor of the enzyme Tyrosinase [22]. So if there's too much of it present, melanin synthesis should come to a halt. The activity of Tyrosinase is also controlled by the expression of two genes: OCA2 and SLC45A2.

Consequently, to approximately simulate the activity levels of Tyrosinase, the following equation was used:

$$\text{Tyrosinase Activity} \propto \text{OCA2} \cdot \text{SLC45A2} / \text{nCysteine} \quad (1)$$

During implementation, the probability of the Tyrosine-Dopaquinone transition firing was set to be a function of the number of tokens of L-Cysteine present, and the values of global variables named OCA2_EXPRESSION and SLC45A2_EXPRESSION, which could range from 0.0 to 1.0.

C. Preferences

The common pre-processor file was also used to implement preferences. In the presence of the enzyme TRP-2, also called DCT or Dopachrome Tautomerase in the literature, DHICA is preferentially used up to create brown eumelanin. If the enzyme is not active, DHI is used to create black eumelanin [23].

Therefore, the probability of the transition Dopachrome-DHI firing was set to be a function of a global variable named TRP2_EXPRESSION, which could range from 0.0 to 1.0.

It is worth mentioning that some papers suggest that TRP-1 too plays a role in deciding whether brown or black eumelanin is produced [24]. This, however, was not included in the model.

D. Colored Tokens

To keep the Petri net model simple, colored tokens were used to distinguish between Eumelanin generated from DHI and that generated from DHICA and IQCA. The common pre-processor file was used to add colors BROWN and BLACK before the transitions Dopachrome-DHICA and Dopachrome-DHI fired.

V. SIMULATION RESULTS

Before we go through the simulation results, let us study Petri Net model's structural properties. Using functions offered by GPenSIM, the invariants in the Petri net were determined.

The following P-invariants were found:

$$p\text{TRP1} - p\text{TRP2} - p\text{Tyrosinase}$$

This was expected because there are enzymes that are never consumed in the pathway. Tokens in these places are always regenerated immediately after transitions involving them fire.

There are no T-invariants found in this Petri net. This was also expected, a series of firings of transitions would never take the chemical reactions back to the original state.

The following subsections analyze the simulation results.

A. No L-Cysteine: Brown or Black Skin

The first experiment involved running the model in the complete absence of L-Cysteine. The expected result was that no Pheomelanin is produced. The expression of OCA2 was set to 0.9, expression of SLC45A2 was set to 0.1, and the expression of TRP-2 was set to 0.7. These values are ideal for the production of large amounts of Eumelanin.

The simulation was run for 1000 time units using GPen-SIM's STOP_AT option. Figure 11 shows the result of the experiment.

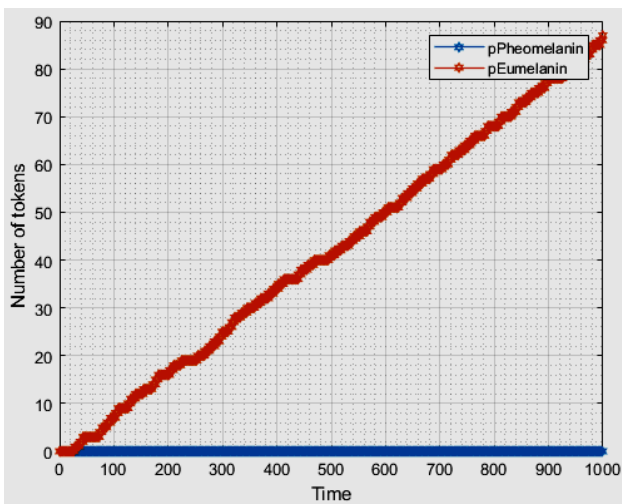

Fig. 11. Experiment 1: No Cysteine

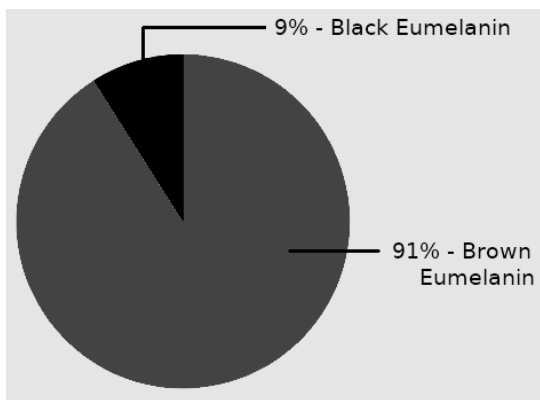

Fig. 12. Relative quantities of black and brown eumelanin

As expected, the model produced nearly 90 units of Eumelanin and no Pheomelanin at all. This number was based on a Tyrosine pool size of 10 units. If there were more Tyrosine available, more Eumelanin would be produced.

Because TRP-2 is relatively active in this experiment, most of the Eumelanin generated was brown. By counting the number of black and brown colored tokens, it was found that 91% of the Eumelanin was brown.

B. A little L-Cysteine: Fair Skin

By setting the Cysteine pool size to 1, a small amount of Cysteine was set to be available in the pathway. All other parameters remained unchanged.

As can be seen in figure 13, the overall amount of melanin produced is slightly lower, because of the inhibitory effect of L-Cysteine on Tyrosinase. Also, the mean ratio of Pheomelanin to Eumelanin is markedly higher. This is generally the case in fair-skinned individuals, whose melanin-producing cells prefer Pheomelanin synthesis [25].

C. Lots of L-Cysteine: Reddish Hair

Because L-Cysteine is toxic, the liver strongly controls the amount of it available in the body [26]. Nevertheless, an experiment was run with an L-Cysteine pool size of 5 units.

As shown in figure 14, the melanin produced is much lower. More importantly, the amount of Pheomelanin now exceeds the amount of eumelanin generated.

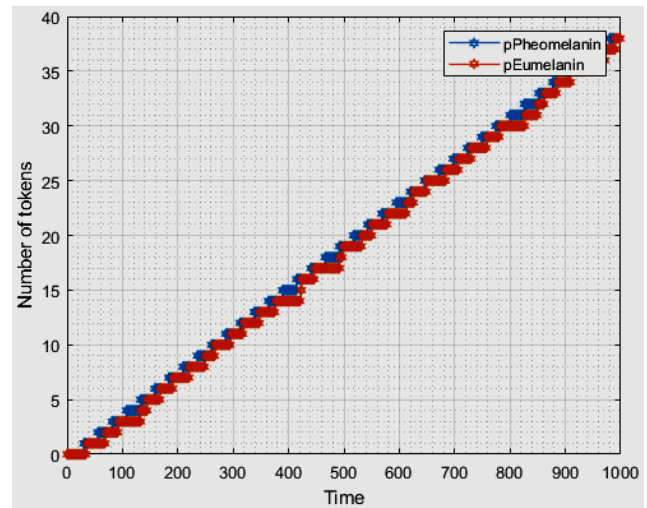

Fig. 13. Experiment 2: A little Cysteine

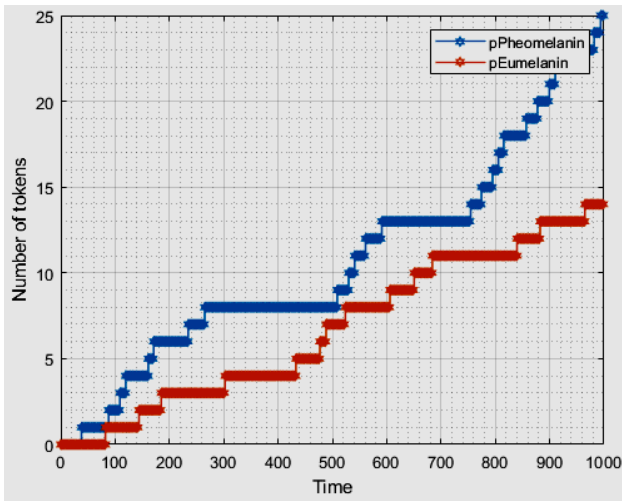

Fig. 14. Experiment 3: Lots of Cysteine

This is seldom the case in the human skin [27]. This condition is only possible in human hair, which is why some individuals have reddish hair.

D. Low OCA2 Expression: Very Fair Skin

By reducing the expression of the OCA2 gene, the activity of Tyrosinase is significantly lowered [28]. To test this behavior, the value of the OCA2_EXPRESSION parameter was set to 0.4. Additionally, the pool size of L-Cysteine was set to 1. Figure 15 shows the result of this experiment.

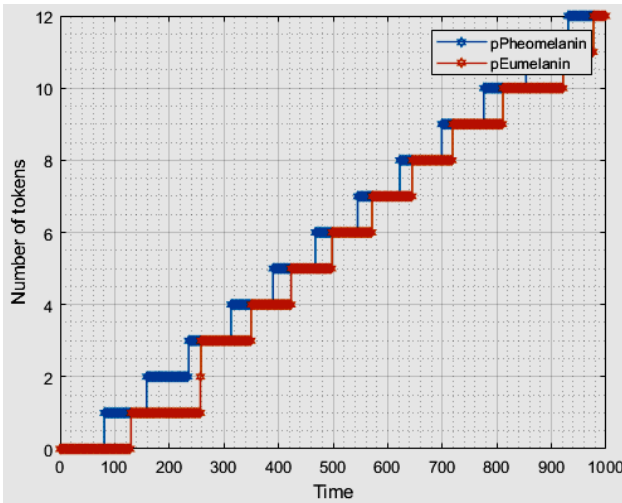

Fig. 15. Experiment 3: Low OCA2 expression

This time too nearly equal amounts of Pheomelanin and Eumelanin are generated, but the overall quantity is far less. An individual with this level of OCA2 expression would have very fair skin and would be quite sensitive to the sun.

E. Simulating Albinism

As a further test, the values of both:

OCA2_EXPRESSION

and

SLC45A2_EXPRESSION

were set to zero. This led to a complete absence of both melanin types. Because, Tyrosinase was fully inactivated, stopping Dopaquinone production. This situation is equivalent to an individual having OCA2 ocular-cutaneous albinism [28].

Another way to stop the melanin synthesis was to remove the initial token in the place for Tyrosinase. This again stopped the production of Dopaquinone. This situation is equivalent to an individual having type 1 albinism, usually called OCA1 oculocutaneous albinism [29].

VI. DISCUSSION

Although literature review reveals Petri net models of several other metabolic pathways, to the best of our knowledge, there are no models of the melanin biosynthesis pathway.

A. Limitations of this work

The Petri net model described in this report only models the conditions at birth. The color of the human skin is also significantly affected by exposure to sunlight. This external factor is not taken into consideration in this model. Furthermore, melanin production irregularities causing skin discoloration and dark spots are quite common in aging individuals. Factors responsible, such as reduced hormonal levels and altered expression of the p53 gene, are not included in this model [30].

The pH levels of the melanocytes play a major role in melanin synthesis. This model handles only one factor that affects pH levels: expression of the OCA2 gene [31].

The current model only uses L-Cysteine to control the synthesis of Pheomelanin. In humans, glutathione too can affect Pheomelanin synthesis. In fact, any sulfhydryl compound can [32]. These compounds can be included to make the model more realistic.

B. Further Improvements

The current model uses generators and pre-processors to control the number of tokens present in the places for L-Tyrosine and L-Cysteine. The numbers are only an approximation, and can only reveal the ratios of Eumelanin and Pheomelanin generated. By implementing Petri net

models for the metabolic pathways for Phenylalanine and Tyrosine metabolism, and for Cysteine formation, and plugging them into this model, its accuracy could be dramatically improved.

There are several external agents, such as H-89 and some common α hydroxy acids such as glycolic acid, which can affect cell pH levels, and thus melanin synthesis. The model could support more use cases by accounting for the presence of such agents.

D-Tyrosine is a compound that competes with L-Tyrosine, thus blocking the melanin synthesis pathway. The current model could include a pool of D-Tyrosine as another parameter. This would allow it to simulate conditions such as the application of modern skin-whitening agents.

VII. CONCLUSION

The colour of the human skin, hair, and eyes is based on the products generated by the melanin synthesis pathway. This paper presents a modular Petri net model of this pathway. Because it is impossible to predict with certainty when a chemical reaction occurs, the Petri net model used random firing times based on exponential distributions. This lead to results that fairly closely modelled the pathway, even without the use of pre-processor files. However, by adding a common pre-processor file, it was possible to more strictly control the behaviour of the transitions in the net. The results obtained from conducting experiments on the Petri net model were in line with real-world experiments.

REFERENCES

- [1] N. G. Jablonski and G. Chaplin, "Human skin pigmentation as an adaptation to uv radiation," *Proceedings of the National Academy of Sciences*, vol. 107, no. Supplement 2, pp. 8962–8968, 2010.
- [2] G. S. Barsh, "What controls variation in human skin color?" *PLoS Biol*, vol. 1, no. 1, p. e27, 2003.
- [3] A. J. Thody, E. M. Higgins, K. Wakamatsu, S. Ito, S. A. Burchill, and J. M. Marks, "Pheomelanin as well as eumelanin is present in human epidermis." *Journal of Investigative Dermatology*, vol. 97, no. 2, 1991.
- [4] G. Hunt, S. Kyne, S. Ito, K. Wakamatsu, C. Todd, and A. J. Thody, "Eumelanin and pheomelanin contents of human epidermis and cultured melanocytes," *Pigment cell research*, vol. 8, no. 4, pp. 202–208, 1995.
- [5] V. N. Reddy, M. L. Mavrovouniotis, M. N. Liebman et al., "Petri net representations in metabolic pathways." in *ISMB*, vol. 93, 1993, pp.328–336.
- [6] I. Koch, B. H. Junker, and M. Heiner, "Application of petri net theory for modelling and validation of the sucrose breakdown pathway in the potato tuber," *Bioinformatics*, vol. 21, no. 7, pp. 1219–1226, 2005.
- [7] M. Heiner, I. Koch, and J. Will, "Model validation of biological pathways using petri nets—demonstrated for apoptosis," *Biosystems*, vol. 75, no. 1-3, pp. 15–28, 2004.
- [8] C. Taubner, B. Mathiak, A. Kupfer, N. Fleischer, and S. Eckstein, "Modelling and simulation of the tr4 pathway with coloured petri nets," in *2006 International Conference of the IEEE Engineering in Medicine and Biology Society*. IEEE, 2006, pp. 2009–2012.
- [9] J. L. Peterson, *Petri net theory and the modeling of systems*. Prentice Hall PTR, 1981.
- [10] R. Davidrajuh, *Modeling discrete-event systems with gpensim: An introduction*. Springer, 2018.
- [11] GPenSIM, "General-purpose Petri net simulator," <http://www.davidrajuh.net/gpensim>, Tech. Rep., 2019, accessed on 20 July 2020.
- [12] R. Davidrajuh, "Extracting petri modules from large and legacy petri net models," *IEEE Access*, vol. 8, pp. 156 539–156 556, 2020.
- [13] —, "A new modular petri net for modeling large discrete-event systems: A proposal based on the literature study," *Computers*, vol. 8, no. 4, p. 83, 2019.
- [14] D. Gilbert, M. Heiner, and S. Lehrack, "A unifying framework for modelling and analysing biochemical pathways using petri nets," in *International Conference on Computational Methods in Systems Biology*. Springer, 2007, pp. 200–216.
- [15] R. Davidrajuh, "Model simplification in petri net models," in *2011 International Conference on Advanced Computer Science and Information Systems*. IEEE, 2011, pp. 189–194.
- [16] T. Inoue, Y. Shiota, and K. Yoshizawa, "Quantum chemical approach to the mechanism for the biological conversion of tyrosine to dopaquinone," *Journal of the American Chemical Society*, vol. 130, no. 50, pp. 16 890–16 897, 2008.
- [17] F. Solano-Muñoz, R. Peñafiel, and J. D. Galindo, "An electrometric method for the determination of tyrosinase activity," *Biochemical Journal*, vol. 229, no. 3, pp. 573–578, 1985.
- [18] J. M. PAWELEK, "After dopachrome?" *Pigment cell research*, vol. 4, no. 2, pp. 53–62, 1991.
- [19] S. Alaluf, A. Heath, N. Carter, D. Atkins, H. Mahalingam, K. Barrett, R. Kolb, and N. Smit, "Variation in melanin content and composition in type v and vi photoexposed and photoprotected human skin: the dominant role of dhi," *Pigment Cell Research*, vol. 14, no. 5, pp. 337–347, 2001.
- [20] Complete code, accessed on 07 January 2021. [Online]. Available: <http://www.davidrajuh.net/gpensim/Pub/2021/UKSim-Melanin>
- [21] S. Ito and K. Wakamatsu, "Chemistry of mixed melanogenesis—pivotal roles of dopaquinone," *Photochemistry and photobiology*, vol. 84, no. 3, pp. 582–592, 2008.
- [22] S. Kermasha, M. Goetghebeur, A. Monfette, M. Metche, and B. Rovel, "Inhibitory effects of cysteine and aromatic acids on tyrosinase activity," *Phytochemistry*, vol. 34, no. 2, pp. 349–353, 1993.
- [23] K. Tsukamoto, I. J. Jackson, K. Urabe, P. M. Montague, and V. Hearing, "A second tyrosinase-related protein, trp-2, is a melanogenic enzyme termed dopachrome tautomerase." *The EMBO journal*, vol. 11, no. 2, pp. 519–526, 1992.
- [24] K. Maeda, Y. Yokokawa, M. Hatao, M. Naganuma, and Y. Tomita, "Comparison of the melanogenesis in human black and light brown melanocytes," *Journal of dermatological science*, vol. 14, no. 3, pp.199–206, 1997.
- [25] F. van Nieuwpoort, N. P. Smit, R. Kolb, H. van der Meulen, H. Koerten, and S. Pavel, "Tyrosine-induced melanogenesis shows differences in morphologic and melanogenic preferences of melanosomes from light and dark skin types," *Journal of investigative dermatology*, vol. 122, no. 5, pp. 1251–1255, 2004.
- [26] M. H. Stipanuk, J. E. Dominy Jr, J.-I. Lee, and R. M. Coloso, "Mammalian cysteine metabolism: new insights into regulation of cysteine metabolism," *The Journal of nutrition*, vol. 136, no. 6, pp. 1652S–1659S, 2006.
- [27] S. Ito and K. Wakamatsu, "Quantitative analysis of eumelanin and pheomelanin in humans, mice, and other animals: a comparative review," *Pigment cell research*, vol. 16, no. 5, pp. 523–531, 2003.
- [28] M. H. BRILLIANT, "The mouse p (pink-eyed dilution) and human p-genes, oculocutaneous albinism type 2 (oca2), and melanosomal ph," *Pigment cell research*, vol. 14, no. 2, pp. 86–93, 2001.
- [29] W. S. Oetting, "The tyrosinase gene and oculocutaneous albinism type 1 (oca1): a model for understanding the molecular biology of melanin formation," *Pigment cell research*, vol. 13, no. 5, pp. 320–325, 2000.
- [30] A. Skoczynska, E. Budzisz, E. Trznadel-Grodzka, and H. Rotsztein, "Melanin and lipofuscin as hallmarks of skin aging," *Advances in*

- Dermatology and Allergology - Postepy Dermatologii i Alergologii, vol. 34, no. 2, p. 97, 2017.
- [31] M. Visser, M. Kayser, and R.-J. Palstra, "Herc2 rs12913832 modulates human pigmentation by attenuating chromatin-loop formation between a long-range enhancer and the oca2 promoter," *Genome research*, vol. 22, no. 3, pp. 446–455, 2012.
- [32] J. Jara, P. Aroca, F. Solano, J. Martinez, and J. Lozano, "The role of sulphhydryl compounds in mammalian melanogenesis: the effect of cysteine and glutathione upon tyrosinase and the intermediates of the pathway," *Biochimica et Biophysica Acta (BBA)-General Subjects*, vol. 967, no. 2, pp. 296–303, 1988.